

TRAFFIC CRASH REPORT

*DENOTES MANDATORY FIELD FOR SUPPLEMENT REPORT

LOCAL REPORT NUMBER *

22-29324

<input checked="" type="checkbox"/> PHOTOS TAKEN	<input type="checkbox"/> OH-2	<input checked="" type="checkbox"/> OH-3	LOCAL INFORMATION	GOOD/GUILFORD
<input type="checkbox"/> SECONDARY CRASH	<input type="checkbox"/> OH-1P	<input checked="" type="checkbox"/> OTHER	REPORTING AGENCY NAME *	NCIC *
<input type="checkbox"/> PRIVATE PROPERTY			Montville Police Department	05213

COUNTY* 52	LOCALITY* 3	LOCATION: CITY, VILLAGE, TOWNSHIP* Guilford (Township of)	CRASH DATE / TIME* 06/03/2022 18:04	CRASH SEVERITY 5
---------------	----------------	--	--	---------------------

ROUTE TYPE	ROUTE NUMBER	PREFIX 1 - NORTH 2 - SOUTH 3 - EAST 4 - WEST	LOCATION ROAD NAME Good	ROAD TYPE RD	LATITUDE DECIMAL DEGREES 41.062500
ROUTE TYPE	ROUTE NUMBER	PREFIX 1 - NORTH 2 - SOUTH 3 - EAST 4 - WEST	REFERENCE ROAD NAME (ROAD, MILEPOST, HOUSE #) Guilford	ROAD TYPE RD	LONGITUDE DECIMAL DEGREES -81.832140

REFERENCE POINT 1 - INTERSECTION 2 - MILE POST 3 - HOUSE # 1	DIRECTION FROM REFERENCE 1 - NORTH 2 - SOUTH 3 - EAST 4 - WEST 3	ROUTE TYPE IR - INTERSTATE ROUTE (TP) US - FEDERAL US ROUTE SR - STATE ROUTE CR - NUMBERED COUNTY ROUTE TR - NUMBERED TOWNSHIP ROUTE	ROAD TYPE AL - ALLEY AV - AVENUE BL - BOULEVARD CR - CIRCLE CT - COURT DR - DRIVE HE - HEIGHTS	ROAD TYPE HW - HIGHWAY LA - LANE MP - MILEPOST OV - OVAL PK - PARKWAY PI - PIKE PL - PLACE	RD - ROAD SQ - SQUARE ST - STREET TE - TERRACE TL - TRAIL WA - WAY	INTERSECTION RELATED <input checked="" type="checkbox"/> WITHIN INTERSECTION OR ON APPROACH <input type="checkbox"/> WITHIN INTERCHANGE AREA NUMBER OF APPROACHES 2
DISTANCE FROM REFERENCE 5.00	DISTANCE UNIT OF MEASURE 1 - MILES 2 - FEET 3 - YARDS 2					ROADWAY <input type="checkbox"/> ROADWAY DIVIDED

LOCATION OF FIRST HARMFUL EVENT 1 - ON ROADWAY 2 - ON SHOULDER 3 - IN MEDIAN 4 - ON ROADSIDE 5 - ON GORE 6 - OUTSIDE TRAFFIC WAY 7 - ON RAMP 8 - OFF RAMP 1	9 - CROSSOVER 10 - DRIVEWAY/ALLEY ACCESS 11 - RAILWAY GRADE CROSSING 12 - SHARED USE PATHS OR TRAILS 13 - BIKE LANE 14 - TOLL BOOTH 99 - OTHER / UNKNOWN	MANNER OF CRASH COLLISION/IMPACT 1 - NOT COLLISION BETWEEN TWO MOTOR VEHICLES IN TRANSPORT 2 - REAR-END 3 - HEAD-ON 4 - REAR-TO-REAR 5 - BACKING 6 - ANGLE 7 - SIDESWIPE, SAME DIRECTION 8 - SIDESWIPE, OPPOSITE DIRECTION 9 - OTHER / UNKNOWN 6	DIRECTION OF TRAVEL 1 - NORTH 2 - SOUTH 3 - EAST 4 - WEST	MEDIAN TYPE 1 - DIVIDED FLUSH MEDIAN (<4 FEET) 2 - DIVIDED FLUSH MEDIAN (≥4 FEET) 3 - DIVIDED, DEPRESSED MEDIAN 4 - DIVIDED, RAISED MEDIAN (ANY TYPE) 9 - OTHER / UNKNOWN
--	--	--	---	--

<input type="checkbox"/> WORK ZONE RELATED <input type="checkbox"/> WORKERS PRESENT <input type="checkbox"/> LAW ENFORCEMENT PRESENT <input type="checkbox"/> ACTIVE SCHOOL ZONE	WORK ZONE TYPE 1 - LANE CLOSURE 2 - LANE SHIFT/ CROSSOVER 3 - WORK ON SHOULDER OR MEDIAN 4 - INTERMITTENT OR MOVING WORK 5 - OTHER	LOCATION OF CRASH IN WORK ZONE 1 - BEFORE THE 1ST WORK ZONE WARNING SIGN 2 - ADVANCE WARNING AREA 3 - TRANSITION AREA 4 - ACTIVITY AREA 5 - TERMINATION AREA	CONTOUR 1	CONDITIONS 1	SURFACE 2
---	---	---	--------------	-----------------	--------------

LIGHT CONDITION 1 - DAYLIGHT 2 - DAWN/DUSK 3 - DARK - LIGHTED ROADWAY 4 - DARK - ROADWAY NOT LIGHTED 5 - DARK - UNKNOWN ROADWAY LIGHTING 9 - OTHER / UNKNOWN 1	WEATHER 1 - CLEAR 2 - CLOUDY 3 - FOG, SMOG, SMOKE 4 - RAIN 5 - SLEET, HAIL 6 - SNOW 7 - SEVERE CROSSWINDS 8 - BLOWING SAND, SOIL, DIRT, SNOW 9 - FREEZING RAIN OR FREEZING DRIZZLE 99 - OTHER / UNKNOWN 2
---	--

NARRATIVE
Unit 1 was traveling west on Good Rd. Unit 2 was traveling south on Guilford Rd. Unit 1 rolled through the stop sign and was struck by Unit 2. Unit 1 sustained disabling damage to the driver's front. Unit 2 sustained functional damage to the passenger front. Heidi's towed Unit 1, and Unit 2 was driven from the scene. The driver of Unit 1 admitted to not coming to a complete stop, and was issued a citation for stop sign.

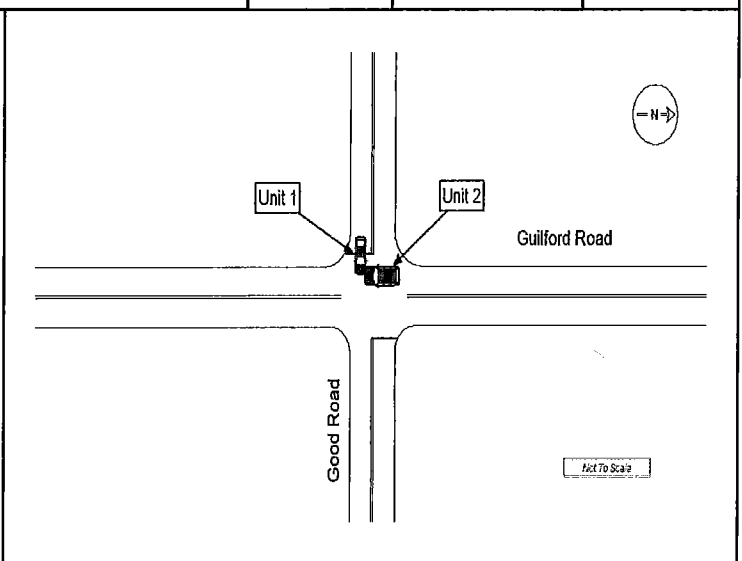

CRASH REPORTED DATE / TIME 06/03/2022 18:04	DISPATCH DATE / TIME 06/03/2022 18:04	ARRIVAL DATE / TIME 06/03/2022 18:13	SCENE CLEARED DATE / TIME 06/03/2022 18:58	REPORT TAKEN BY <input checked="" type="checkbox"/> POLICE AGENCY <input type="checkbox"/> MOTORIST
TOTAL TIME ROADWAY CLOSED	OTHER INVESTIGATION TIME 30	TOTAL MINUTES 84	OFFICER'S NAME* Eckstine, Joel OFFICER'S BADGE NUMBER* 1618	CHECKED BY OFFICER'S NAME* Searle, Cory CHECKED BY OFFICER'S BADGE NUMBER* 1605
				<input type="checkbox"/> SUPPLEMENT (CORRECTION OR ADDITION TO AN EXISTING REPORT SENT TO ODPS)

OWNER # 1 **OWNER NAME:** LAST, FIRST, MIDDLE (SAME AS DRIVER)
OWNER ADDRESS: STREET, CITY, STATE, ZIP (SAME AS DRIVER)
 3790 GOOD ROAD, SEVILLE, OH, 44273
COMMERCIAL CARRIER: NAME, ADDRESS, CITY, STATE, ZIP **COMMERCIAL CARRIER PHONE:** INCLUDE AREA CODE

LP STATE OH **LICENSE PLATE #** 209YVV **VEHICLE IDENTIFICATION #** JN1A2EH7GM934680 **VEHICLE YEAR** 2016 **VEHICLE MAKE** NISSAN
 INSURANCE VERIFIED **INSURANCE COMPANY** USAA **INSURANCE POLICY #** 10948149 **COLOR** BLK **VEHICLE MODEL** 370Z

COMMERCIAL **GOVERNMENT** **IN EMERGENCY RESPONSE** **US DOT #** **TOWED BY: COMPANY NAME** HEIDI'S TOWING
 INTERLOCK DEVICE EQUIPPED **HIT/SKIP UNIT** **# OCCUPANTS** **VEHICLE WEIGHT GVWR/GCWR** **HAZARDOUS MATERIAL CLASS #** **PLACARD ID #**

UNIT TYPE 1 - PASSENGER CAR 6 - VAN (9-15 SEATS) 12 - GOLF CART 18 - LIMO (LIVERY VEHICLE) 23 - PEDESTRIAN/SKATER
 2 - PASSENGER VAN (MINIVAN) 7 - MOTORCYCLE 2-WHEELED 13 - SNOWMOBILE 19 - BUS (16+ PASSENGERS) 24 - WHEELCHAIR (ANY TYPE)
 3 - SPORT UTILITY VEHICLE 8 - MOTORCYCLE 3-WHEELED 14 - SINGLE UNIT TRUCK 20 - OTHER VEHICLE 25 - OTHER NON-MOTORIST
 4 - PICK UP 9 - AUTOCYCLE 15 - SEMI-TRACTOR 21 - HEAVY EQUIPMENT 26 - BICYCLE
 5 - CARGO VAN 10 - MOPED OR MOTORIZED BICYCLE 16 - FARM EQUIPMENT 22 - ANIMAL WITH RIDER OR ANIMAL-DRAWN VEHICLE 27 - TRAIN
 11 - ALL TERRAIN VEHICLE (ATV/UTV) 17 - MOTORHOME 99 - UNKNOWN OR HIT/SKIP

WAS VEHICLE OPERATING IN AUTONOMOUS MODE WHEN CRASH OCCURRED? 0 - NO AUTOMATION 3 - CONDITIONAL AUTOMATION 9 - UNKNOWN
 1 - YES 2 - NO 9 - OTHER / UNKNOWN **AUTONOMOUS MODE LEVEL** 1 - DRIVER ASSISTANCE 4 - HIGH AUTOMATION
 2 - PARTIAL AUTOMATION 5 - FULL AUTOMATION

SPECIAL FUNCTION 1 - NONE 6 - BUS - CHARTER/TOUR 11 - FIRE 16 - FARM 21 - MAIL CARRIER
 2 - TAXI 7 - BUS - INTERCITY 12 - MILITARY 17 - MOWING 99 - OTHER / UNKNOWN
 3 - ELECTRONIC RIDE SHARING 8 - BUS - SHUTTLE 13 - POLICE 18 - SNOW REMOVAL
 4 - SCHOOL TRANSPORT 9 - BUS - OTHER 14 - PUBLIC UTILITY 19 - TOWING
 5 - BUS - TRANSIT/COMMUTER 10 - AMBULANCE 15 - CONSTRUCTION EQUIP. 20 - SAFETY SERVICE PATROL

CARGO BODY TYPE 1 - NO CARGO BODY TYPE / NOT APPLICABLE 4 - LOGGING 7 - GRAIN/CHIPS/GRAVEL 11 - DUMP 99 - OTHER / UNKNOWN
 2 - BUS 5 - INTERMODAL CONTAINER CHASSIS 8 - POLE 12 - CONCRETE MIXER
 3 - VEHICLE TOWING ANOTHER MOTOR VEHICLE 6 - CARGOVAN /ENCLOSED BOX 9 - CARGO TANK 13 - AUTO TRANSPORTER
 10 - FLAT BED 14 - GARBAGE/REFUSE

VEHICLE DEFECTS 1 - TURN SIGNALS 4 - BRAKES 7 - WORN OR SLICK TIRES 9 - MOTOR TROUBLE 99 - OTHER / UNKNOWN
 2 - HEAD LAMPS 5 - STEERING 8 - TRAILER EQUIPMENT DEFECTIVE 10 - DISABLED FROM PRIOR ACCIDENT
 3 - TAIL LAMPS 6 - TIRE BLOWOUT

NON-MOTORIST LOCATION 1 - INTERSECTION - MARKED CROSSWALK 4 - MIDBLOCK - MARKED CROSSWALK 7 - SHOULDER/ROADSIDE 10 - DRIVEWAY ACCESS 99 - OTHER / UNKNOWN
 2 - INTERSECTION - UNMARKED CROSSWALK 5 - TRAVEL LANE - OTHER LOCATION 8 - SIDEWALK 11 - SHARED USE PATHS OR TRAILS
 3 - INTERSECTION - OTHER 6 - BICYCLE LANE 9 - MEDIAN/CROSSING ISLAND 12 - FIRST RESPONDER AT INCIDENT SCENE

ACTION 1 - NON-CONTACT 1 - STRAIGHT AHEAD 9 - LEAVING TRAFFIC LANE 15 - WALKING, RUNNING, JOGGING, PLAYING 21 - STANDING OUTSIDE DISABLED VEHICLE
 2 - NON-COLLISION 2 - BACKING 10 - PARKED 16 - WORKING 99 - OTHER / UNKNOWN
 3 - STRIKING 3 - CHANGING LANES 11 - SLOWING OR STOPPED IN TRAFFIC 17 - PUSHING VEHICLE
 4 - STRUCK 4 - OVERTAKING/PASSING 12 - DRIVERLESS 18 - APPROACHING OR LEAVING VEHICLE
 5 - BOTH STRIKING & STRUCK 5 - MAKING RIGHT TURN 13 - NEGOTIATING A CURVE 19 - STANDING
 9 - OTHER / UNKNOWN 8 - ENTERING TRAFFIC LANE 14 - ENTERING OR CROSSING SPECIFIED LOCATION 20 - OTHER NON-MOTORIST

CONTRIBUTING CIRCUMSTANCES 1 - NONE 8 - FOLLOWING TOO CLOSE /ACDA 13 - IMPROPER START FROM A PARKED POSITION 18 - OPERATING DEFECTIVE EQUIPMENT 23 - OPENING DOOR INTO ROADWAY
 2 - FAILURE TO YIELD 9 - IMPROPER LANE CHANGE 14 - STOPPED OR PARKED ILLEGALLY 19 - LOAD SHIFTING /FALLING/SPILLING 99 - OTHER IMPROPER ACTION
 3 - RAN RED LIGHT 10 - IMPROPER PASSING 15 - SWERVING TO AVOID 20 - IMPROPER CROSSING
 4 - RAN STOP SIGN 11 - DROVE OFF ROAD 16 - WRONG WAY 21 - LYING IN ROADWAY
 5 - UNSAFE SPEED 12 - IMPROPER BACKING 17 - VISION OBSTRUCTION 22 - NOT DISCERNIBLE
 6 - IMPROPER TURN 7 - LEFT OF CENTER

SEQUENCE OF EVENTS 1 - OVERTURN/ROLLOVER 7 - SEPARATION OF UNITS 12 - DOWNHILL RUNAWAY 19 - ANIMAL - OTHER 23 - STRUCK BY FALLING, SHIFTING CARGO OR ANYTHING SET IN MOTION BY A MOTOR VEHICLE
 2 - FIRE/EXPLOSION 8 - RAN OFF ROAD RIGHT 13 - OTHER NON-COLLISION 20 - MOTOR VEHICLE IN TRANSPORT
 3 - IMMERSION 9 - RAN OFF ROAD LEFT 14 - PEDESTRIAN 21 - PARKED MOTOR VEHICLE
 4 - JACKKNIFE 10 - CROSS MEDIAN 15 - PEDALCYCLE 22 - WORK ZONE MAINTENANCE EQUIPMENT
 5 - CARGO /EQUIPMENT LOSS OR SHIFT 11 - CROSS CENTERLINE - OPPOSITE DIRECTION OF TRAVEL 16 - RAILWAY VEHICLE 17 - ANIMAL - FARM
 6 - EQUIPMENT FAILURE 6 - EQUIPMENT FAILURE 18 - ANIMAL - DEER

EVENTS 25 - IMPACT ATTENUATOR / CRASH CUSHION 31 - GUARDRAIL END 38 - OVERHEAD SIGN POST 45 - EMBANKMENT 52 - BUILDING
 26 - BRIDGE OVERHEAD STRUCTURE 32 - PORTABLE BARRIER 39 - LIGHT / LUMINARIES SUPPORT 46 - FENCE 53 - TUNNEL
 27 - BRIDGE PIER OR ABUTMENT 33 - MEDIAN CABLE BARRIER 40 - UTILITY POLE 47 - MAILBOX 54 - OTHER FIXED OBJECT
 28 - BRIDGE PARAPET 34 - MEDIAN GUARDRAIL BARRIER 41 - OTHER POST, POLE OR SUPPORT 48 - TREE 99 - OTHER / UNKNOWN
 29 - BRIDGE RAIL 35 - MEDIAN CONCRETE BARRIER 42 - CULVERT 49 - FIRE HYDRANT 50 - WORK ZONE MAINTENANCE EQUIPMENT
 30 - GUARDRAIL FACE 36 - MEDIAN OTHER BARRIER 43 - CURB 51 - WALL

FIRST HARMFUL EVENT 1 **MOST HARMFUL EVENT** 1

LOCAL REPORT NUMBER 22-29324

DAMAGE
DAMAGE SCALE
 1 - NONE 3 - FUNCTIONAL DAMAGE
 2 - MINOR DAMAGE 4 - DISABLING DAMAGE
 9 - UNKNOWN
 [4]

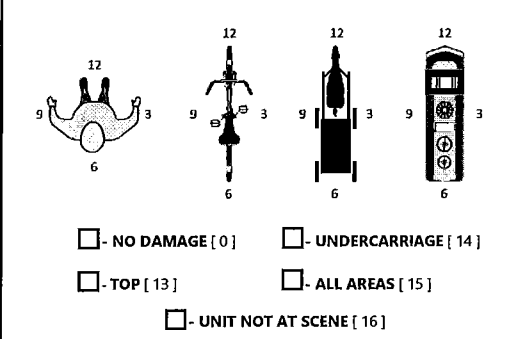
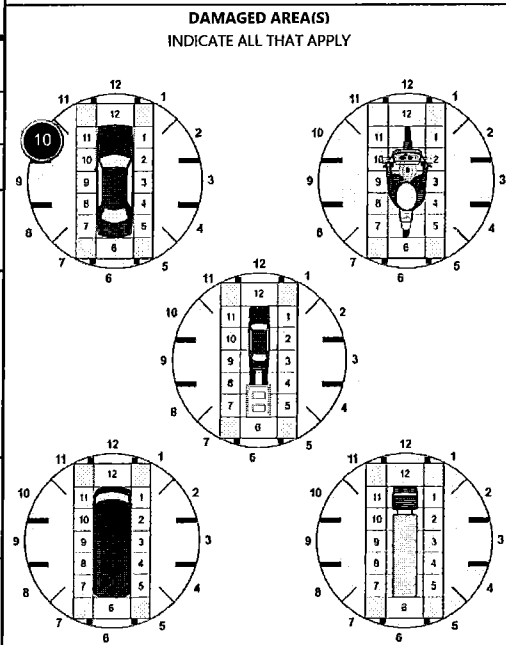

INITIAL POINT OF CONTACT
 0 - NO DAMAGE 14 - UNDERCARRIAGE
 1-12 - REFER TO UNIT DIAGRAM 15 - VEHICLE NOT AT SCENE
 99 - UNKNOWN
 13 - TOP
 [11]

TRAFFIC
TRAFFICWAY FLOW 1 - ONE-WAY 2 - TWO-WAY [2]
TRAFFIC CONTROL 1 - ROUNDABOUT 4 - STOP SIGN 2 - SIGNAL 5 - YIELD SIGN 3 - FLASHER 6 - NO CONTROL [4]

OF THROUGH LANES ON ROAD [2]
RAIL GRADE CROSSING 1 - NOT INVOLVED 2 - INVOLVED-ACTIVE CROSSING 3 - INVOLVED-PASSIVE CROSSING

UNIT / NON-MOTORIST DIRECTION
 FROM [4] TO [3]
 1 - NORTH 5 - NORTHEAST 2 - SOUTH 6 - NORTHWEST 3 - EAST 7 - SOUTHWEST 4 - WEST 8 - SOUTHWEST 9 - OTHER / UNKNOWN

UNIT SPEED [0] **DETECTED SPEED** 1 - STATED / ESTIMATED SPEED
POSTED SPEED [50] 2 - CALCULATED / EDR
 3 - UNDETERMINED

UNIT # 2 **OWNER NAME:** LAST, FIRST, MIDDLE (SAME AS DRIVER)
OWNER PHONE: INCLUDE AREA CODE (SAME AS DRIVER)
 RATLIFF, REBECCA, A

OWNER ADDRESS: STREET, CITY, STATE, ZIP (SAME AS DRIVER)
 9439 ACME RD, SEVILLE, OH, 44273

COMMERCIAL CARRIER: NAME, ADDRESS, CITY, STATE, ZIP **COMMERCIAL CARRIER PHONE:** INCLUDE AREA CODE

LP STATE OH **LICENSE PLATE #** GTE2301 **VEHICLE IDENTIFICATION #** 2FMDK49C19BA52695 **VEHICLE YEAR** 2009 **VEHICLE MAKE** FORD

INSURANCE VERIFIED **INSURANCE COMPANY** OHIO MUTUAL-WILDE CORP **INSURANCE POLICY #** AAO-0021065-03 **COLOR** BLK **VEHICLE MODEL** EDGE

COMMERCIAL **GOVERNMENT** **IN EMERGENCY RESPONSE** **US DOT #** **TOWED BY:** COMPANY NAME

INTERLOCK DEVICE EQUIPPED **HIT/SKIP UNIT** **# OCCUPANTS** **VEHICLE WEIGHT GVWR/GCWR**
 1 - ≤10K LBS.
 2 - 10,001 - 26K LBS.
 3 - > 26K LBS.

MATERIAL RELEASED **HAZARDOUS MATERIAL CLASS #** **PLACARD ID #**

UNIT TYPE 3

1 - PASSENGER CAR	6 - VAN (9-15 SEATS)	12 - GOLF CART	18 - LIMO (LIVERY VEHICLE)	23 - PEDESTRIAN/SKATER
2 - PASSENGER VAN (MINIVAN)	7 - MOTORCYCLE 2-WHEELED	13 - SNOWMOBILE	19 - BUS (16+ PASSENGERS)	24 - WHEELCHAIR (ANY TYPE)
3 - SPORT UTILITY VEHICLE	8 - MOTORCYCLE 3-WHEELED	14 - SINGLE UNIT TRUCK	20 - OTHER VEHICLE	25 - OTHER NON-MOTORIST
4 - PICK UP	9 - AUTOCYCLE	15 - SEMI-TRACTOR	21 - HEAVY EQUIPMENT	26 - BICYCLE
5 - CARGO VAN	10 - MOPED OR MOTORIZED BICYCLE	16 - FARM EQUIPMENT	22 - ANIMAL WITH RIDER OR ANIMAL-DRAWN VEHICLE	27 - TRAIN
	11 - ALL TERRAIN VEHICLE (ATV/UTV)	17 - MOTORHOME	99 - UNKNOWN OR HIT/SKIP	

OF TRAILING UNITS

WAS VEHICLE OPERATING IN AUTONOMOUS MODE WHEN CRASH OCCURRED? 2

AUTONOMOUS MODE LEVEL 0

0 - NO AUTOMATION	3 - CONDITIONAL AUTOMATION	9 - UNKNOWN
1 - DRIVER ASSISTANCE	4 - HIGH AUTOMATION	
2 - PARTIAL AUTOMATION	5 - FULL AUTOMATION	

SPECIAL FUNCTION 1

1 - NONE	6 - BUS - CHARTER/TOUR	11 - FIRE	16 - FARM	21 - MAIL CARRIER
2 - TAXI	7 - BUS - INTERCITY	12 - MILITARY	17 - MOWING	99 - OTHER / UNKNOWN
3 - ELECTRONIC RIDE SHARING	8 - BUS - SHUTTLE	13 - POLICE	18 - SNOW REMOVAL	
4 - SCHOOL TRANSPORT	9 - BUS - OTHER	14 - PUBLIC UTILITY	19 - TOWING	
5 - BUS - TRANSIT/COMMUTER	10 - AMBULANCE	15 - CONSTRUCTION EQUIP.	20 - SAFETY SERVICE PATROL	

CARGO BODY TYPE 1

1 - NO CARGO BODY TYPE / NOT APPLICABLE	4 - LOGGING	7 - GRAIN/CHIPS/GRAVEL	11 - DUMP	99 - OTHER / UNKNOWN
2 - BUS	5 - INTERMODAL CONTAINER CHASSIS	8 - POLE	12 - CONCRETE MIXER	
3 - VEHICLE TOWING ANOTHER MOTOR VEHICLE	6 - CARGOVAN /ENCLOSED BOX	9 - CARGO TANK	13 - AUTO TRANSPORTER	
		10 - FLAT BED	14 - GARBAGE/REFUSE	

VEHICLE DEFECTS

1 - TURN SIGNALS	4 - BRAKES	7 - WORN OR SLICK TIRES	9 - MOTOR TROUBLE	99 - OTHER / UNKNOWN
2 - HEAD LAMPS	5 - STEERING	8 - TRAILER EQUIPMENT DEFECTIVE	10 - DISABLED FROM PRIOR ACCIDENT	
3 - TAIL LAMPS	6 - TIRE BLOWOUT			

NON-MOTORIST LOCATION

1 - INTERSECTION - MARKED CROSSWALK	4 - MIDBLOCK - MARKED CROSSWALK	7 - SHOULDER/ROADSIDE	10 - DRIVEWAY ACCESS	99 - OTHER / UNKNOWN
2 - INTERSECTION - UNMARKED CROSSWALK	5 - TRAVEL LANE - OTHER LOCATION	8 - SIDEWALK	11 - SHARED USE PATHS OR TRAILS	
3 - INTERSECTION - OTHER	6 - BICYCLE LANE	9 - MEDIAN/CROSSING ISLAND	12 - FIRST RESPONDER AT INCIDENT SCENE	

ACTION 3 **PRE-CRASH ACTIONS** 1

1 - NON-CONTACT	1 - STRAIGHT AHEAD	9 - LEAVING TRAFFIC LANE	15 - WALKING, RUNNING, JOGGING, PLAYING	21 - STANDING OUTSIDE DISABLED VEHICLE
2 - NON-COLLISION	2 - BACKING	10 - PARKED	16 - WORKING	99 - OTHER / UNKNOWN
3 - STRIKING	3 - CHANGING LANES	11 - SLOWING OR STOPPED IN TRAFFIC	17 - PUSHING VEHICLE	
4 - STRUCK	4 - OVERTAKING/PASSING	12 - DRIVERLESS	18 - APPROACHING OR LEAVING VEHICLE	
5 - BOTH STRIKING & STRUCK	5 - MAKING RIGHT TURN	13 - NEGOTIATING A CURVE	19 - STANDING	
9 - OTHER / UNKNOWN	6 - MAKING LEFT TURN	14 - ENTERING OR CROSSING SPECIFIED LOCATION	20 - OTHER NON-MOTORIST	
	7 - MAKING U-TURN			
	8 - ENTERING TRAFFIC LANE			

CONTRIBUTING CIRCUMSTANCES 1

1 - NONE	8 - FOLLOWING TOO CLOSE /ACDA	13 - IMPROPER START FROM A PARKED POSITION	18 - OPERATING DEFECTIVE EQUIPMENT	23 - OPENING DOOR INTO ROADWAY
2 - FAILURE TO YIELD	9 - IMPROPER LANE CHANGE	14 - STOPPED OR PARKED ILLEGALLY	19 - LOAD SHIFTING /FALLING/SPILLING	99 - OTHER IMPROPER ACTION
3 - RAN RED LIGHT	10 - IMPROPER PASSING	15 - SWERVING TO AVOID	20 - IMPROPER CROSSING	
4 - RAN STOP SIGN	11 - DROVE OFF ROAD	16 - WRONG WAY	21 - LYING IN ROADWAY	
5 - UNSAFE SPEED	12 - IMPROPER BACKING	17 - VISION OBSTRUCTION	22 - NOT DISCERNIBLE	
6 - IMPROPER TURN				
7 - LEFT OF CENTER				

SEQUENCE OF EVENTS

1	20	1 - OVERTURN/ROLLOVER	7 - SEPARATION OF UNITS	12 - DOWNHILL RUNAWAY	19 - ANIMAL - OTHER	23 - STRUCK BY FALLING, SHIFTING CARGO OR ANYTHING SET IN MOTION BY A MOTOR VEHICLE
2		2 - FIRE/EXPLOSION	8 - RAN OFF ROAD RIGHT	13 - OTHER NON-COLLISION	20 - MOTOR VEHICLE IN TRANSPORT	
3		3 - IMMERSION	9 - RAN OFF ROAD LEFT	14 - PEDESTRIAN	21 - PARKED MOTOR VEHICLE	
4		4 - JACKKNIFE	10 - CROSS MEDIAN	15 - PEDALCYCLE	22 - WORK ZONE MAINTENANCE EQUIPMENT	
5		5 - CARGO /EQUIPMENT LOSS OR SHIFT	11 - CROSS CENTERLINE - OPPOSITE DIRECTION OF TRAVEL	16 - RAILWAY VEHICLE	23 - STRUCK BY FALLING, SHIFTING CARGO OR ANYTHING SET IN MOTION BY A MOTOR VEHICLE	
6		6 - EQUIPMENT FAILURE		17 - ANIMAL - FARM	24 - OTHER MOVABLE OBJECT	
				18 - ANIMAL - DEER		

COLLISION WITH FIXED OBJECT - STRUCK

25 - IMPACT ATTENUATOR / CRASH CUSHION	31 - GUARDRAIL END	38 - OVERHEAD SIGN POST	45 - EMBANKMENT
26 - BRIDGE OVERHEAD STRUCTURE	32 - PORTABLE BARRIER	39 - LIGHT / LUMINARIES	46 - FENCE
27 - BRIDGE PIER OR ABUTMENT	33 - MEDIAN CABLE BARRIER	40 - UTILITY POLE	47 - MAILBOX
28 - BRIDGE PARAPET	34 - MEDIAN GUARDRAIL BARRIER	41 - OTHER POST, POLE OR SUPPORT	48 - TREE
29 - BRIDGE RAIL	35 - MEDIAN CONCRETE BARRIER	42 - CULVERT	49 - FIRE HYDRANT
30 - GUARDRAIL FACE	36 - MEDIAN OTHER BARRIER	43 - CURB	50 - WORK ZONE MAINTENANCE EQUIPMENT
	37 - TRAFFIC SIGN POST	44 - DITCH	51 - WALL
			52 - BUILDING
			53 - TUNNEL
			54 - OTHER FIXED OBJECT
			99 - OTHER / UNKNOWN

FIRST HARMFUL EVENT 1 **MOST HARMFUL EVENT** 1

LOCAL REPORT NUMBER
22-29324

DAMAGE

DAMAGE SCALE

1 - NONE	3 - FUNCTIONAL DAMAGE
2 - MINOR DAMAGE	4 - DISABLING DAMAGE
9 - UNKNOWN	

3

DAMAGED AREA(S)
INDICATE ALL THAT APPLY

NO DAMAGE [0] **UNDERCARRIAGE** [14]

TOP [13] **ALL AREAS** [15]

UNIT NOT AT SCENE [16]

INITIAL POINT OF CONTACT

0 - NO DAMAGE	14 - UNDERCARRIAGE
1-12 - REFER TO UNIT DIAGRAM	15 - VEHICLE NOT AT SCENE
13 - TOP	99 - UNKNOWN

12

TRAFFIC

TRAFFICWAY FLOW	TRAFFIC CONTROL
1 - ONE-WAY	1 - ROUNDABOUT
2 - TWO-WAY	4 - STOP SIGN
	5 - YIELD SIGN
	6 - NO CONTROL

2

OF THROUGH LANES ON ROAD 2

RAIL GRADE CROSSING

1 - NOT INVOLVED
2 - INVOLVED-ACTIVE CROSSING
3 - INVOLVED-PASSIVE CROSSING

UNIT / NON-MOTORIST DIRECTION

1 - NORTH	5 - NORTHEAST
2 - SOUTH	6 - NORTHWEST
3 - EAST	7 - SOUTHEAST
4 - WEST	8 - SOUTHWEST
9 - OTHER / UNKNOWN	

FROM 1 TO 2

UNIT SPEED 50

POSTED SPEED 50

DETECTED SPEED

1 - STATED / ESTIMATED SPEED
2 - CALCULATED / EDR
3 - UNDETERMINED

1



MOTORIST / Non-MOTORIST

LOCAL REPORT NUMBER
22-29324

UNIT # 1 NAME: LAST, FIRST, MIDDLE
JEFFERIRES, IAN, R

DATE OF BIRTH 03/12/1980 AGE 42 GENDER M

ADDRESS: STREET, CITY, STATE, ZIP
3790 GOOD ROAD, SEVILLE, OH, 44273

CONTACT PHONE - INCLUDE AREA CODE
[REDACTED]

INJURIES 5 INJURED TAKEN BY 1 EMS AGENCY (NAME) [REDACTED] INJURED TAKEN TO: MEDICAL FACILITY (NAME, CITY) [REDACTED] SAFETY EQUIPMENT USED 4

DOT-COMPLIANT MC HELMET [] SEATING POSITION 1 AIR BAG USAGE 1 EJECTION 1 TRAPPED 1

OL STATE OH OPERATOR LICENSE NUMBER [REDACTED] OFFENSE CHARGED 4511.43 LOCAL CODE [] OFFENSE DESCRIPTION RIGHT-OF-WAY AT THROUGH HIGHW CITATION NUMBER Y42360

OL CLASS 4 ENDORSEMENT M RESTRICTION SELECT UP TO 3 DRIVER DISTRACTED BY 1 ALCOHOL / DRUG SUSPECTED [] ALCOHOL [] MARIJUANA [] OTHER DRUG [] CONDITION 1

ALCOHOL TEST STATUS 1 TYPE 1 VALUE . DRUG TEST(S) STATUS 1 TYPE 1 RESULTS SELECT UP TO 4

UNIT # 2 NAME: LAST, FIRST, MIDDLE
RATLIFF, REBECCA, A

DATE OF BIRTH 02/04/1988 AGE 34 GENDER F

ADDRESS: STREET, CITY, STATE, ZIP
9439 ACME RD, SEVILLE, OH, 44273

CONTACT PHONE - INCLUDE AREA CODE
[REDACTED]

INJURIES 5 INJURED TAKEN BY 1 EMS AGENCY (NAME) [REDACTED] INJURED TAKEN TO: MEDICAL FACILITY (NAME, CITY) [REDACTED] SAFETY EQUIPMENT USED 4

DOT-COMPLIANT MC HELMET [] SEATING POSITION 1 AIR BAG USAGE 1 EJECTION 1 TRAPPED 1

OL STATE OH OPERATOR LICENSE NUMBER [REDACTED] OFFENSE CHARGED [REDACTED] LOCAL CODE [] OFFENSE DESCRIPTION [REDACTED] CITATION NUMBER [REDACTED]

OL CLASS 4 ENDORSEMENT [REDACTED] RESTRICTION SELECT UP TO 3 DRIVER DISTRACTED BY 1 ALCOHOL / DRUG SUSPECTED [] ALCOHOL [] MARIJUANA [] OTHER DRUG [] CONDITION 1

ALCOHOL TEST STATUS 1 TYPE 1 VALUE . DRUG TEST(S) STATUS 1 TYPE 1 RESULTS SELECT UP TO 4

UNIT # [REDACTED] NAME: LAST, FIRST, MIDDLE [REDACTED]

DATE OF BIRTH [REDACTED] AGE [REDACTED] GENDER [REDACTED]

ADDRESS: STREET, CITY, STATE, ZIP [REDACTED]

CONTACT PHONE - INCLUDE AREA CODE [REDACTED]

INJURIES [REDACTED] INJURED TAKEN BY [REDACTED] EMS AGENCY (NAME) [REDACTED] INJURED TAKEN TO: MEDICAL FACILITY (NAME, CITY) [REDACTED] SAFETY EQUIPMENT USED [REDACTED]

DOT-COMPLIANT MC HELMET [] SEATING POSITION [REDACTED] AIR BAG USAGE [REDACTED] EJECTION [REDACTED] TRAPPED [REDACTED]

OL STATE [REDACTED] OPERATOR LICENSE NUMBER [REDACTED] OFFENSE CHARGED [REDACTED] LOCAL CODE [] OFFENSE DESCRIPTION [REDACTED] CITATION NUMBER [REDACTED]

OL CLASS [REDACTED] ENDORSEMENT [REDACTED] RESTRICTION SELECT UP TO 3 DRIVER DISTRACTED BY [REDACTED] ALCOHOL / DRUG SUSPECTED [] ALCOHOL [] MARIJUANA [] OTHER DRUG [] CONDITION [REDACTED]

ALCOHOL TEST STATUS [REDACTED] TYPE [REDACTED] VALUE [REDACTED] DRUG TEST(S) STATUS [REDACTED] TYPE [REDACTED] RESULTS SELECT UP TO 4

INJURIES	SEATING POSITION	AIR BAG	OL CLASS	OL RESTRICTION(S)	DRIVER DISTRACTION	TEST STATUS
1 - FATAL 2 - SUSPECTED SERIOUS INJURY 3 - SUSPECTED MINOR INJURY 4 - POSSIBLE INJURY 5 - NO APPARENT INJURY	1 - FRONT - LEFT SIDE (MOTORCYCLE DRIVER) 2 - FRONT - MIDDLE 3 - FRONT - RIGHT SIDE 4 - SECOND - LEFT SIDE (MOTORCYCLE PASSENGER) 5 - SECOND - MIDDLE 6 - SECOND - RIGHT SIDE 7 - THIRD - LEFT SIDE (MOTORCYCLE SIDE CAR) 8 - THIRD - MIDDLE 9 - THIRD - RIGHT SIDE 10 - SLEEPER SECTION OF TRUCK CAB 11 - PASSENGER IN OTHER ENCLOSED CARGO AREA (NON-TRAILING UNIT, BUS, PICK-UP WITH CAP) 12 - PASSENGER IN UNENCLOSED CARGO AREA 13 - TRAILING UNIT 14 - RIDING ON VEHICLE EXTERIOR 15 - NON-MOTORIST 99 - OTHER / UNKNOWN	1 - NOT DEPLOYED 2 - DEPLOYED FRONT 3 - DEPLOYED SIDE 4 - DEPLOYED BOTH FRONT/SIDE 5 - NOT APPLICABLE 9 - DEPLOYMENT UNKNOWN	1 - CLASS A 2 - CLASS B 3 - CLASS C 4 - REGULAR CLASS (OHIO = D) 5 - M/C MOPED ONLY 6 - NO VALID OL	1 - ALCOHOL INTERLOCK DEVICE 2 - CDL INTRASTATE ONLY 3 - CORRECTIVE LENSES 4 - FARM WAIVER 5 - EXCEPT CLASS A BUS 6 - EXCEPT CLASS A & CLASS B BUS 7 - EXCEPT TRACTOR-TRAILER 8 - INTERMEDIATE LICENSE RESTRICTIONS 9 - LEARNER'S PERMIT RESTRICTIONS 10 - LIMITED TO DAYLIGHT ONLY 11 - LIMITED TO EMPLOYMENT 12 - LIMITED - OTHER 13 - MECHANICAL DEVICES (SPECIAL BRAKES, HAND CONTROLS, OR OTHER ADAPTIVE DEVICES) 14 - MILITARY VEHICLES ONLY 15 - MOTOR VEHICLES WITHOUT AIR BRAKES 16 - OUTSIDE MIRROR 17 - PROSTHETIC AID 18 - OTHER	1 - NOT DISTRACTED 2 - MANUALLY OPERATING AN ELECTRONIC COMMUNICATION DEVICE (TEXTING, TYPING, TALKING) 3 - TALKING ON HANDS-FREE COMMUNICATION DEVICE 4 - TALKING ON HAND-HELD COMMUNICATION DEVICE 5 - OTHER ACTIVITY WITH AN ELECTRONIC DEVICE 6 - PASSENGER 7 - OTHER DISTRACTION INSIDE THE VEHICLE 8 - OTHER DISTRACTION OUTSIDE THE VEHICLE 9 - OTHER / UNKNOWN	1 - NONE GIVEN 2 - TEST REFUSED 3 - TEST GIVEN, CONTAMINATED SAMPLE / UNUSABLE 4 - TEST GIVEN, RESULTS KNOWN 5 - TEST GIVEN, RESULTS UNKNOWN
INJURIES TAKEN BY 1 - NOT TRANSPORTED /TREATED AT SCENE 2 - EMS 3 - POLICE 9 - OTHER / UNKNOWN		EJECTION 1 - NOT EJECTED 2 - PARTIALLY EJECTED 3 - TOTALLY EJECTED 4 - NOT APPLICABLE	OL ENDORSEMENT H - HAZMAT M - MOTORCYCLE P - PASSENGER N - TANKER Q - MOTOR SCOOTER R - THREE-WHEEL MOTORCYCLE S - SCHOOL BUS T - DOUBLE & TRIPLE TRAILERS X - TANKER / HAZMAT			ALCOHOL TEST TYPE 1 - NONE 2 - BLOOD 3 - URINE 4 - BREATH 5 - OTHER
SAFETY EQUIPMENT 1 - NONE USED 2 - SHOULDER BELT ONLY USED 3 - LAP BELT ONLY USED 4 - SHOULDER & LAP BELT USED 5 - CHILD RESTRAINT SYSTEM - FORWARD FACING 6 - CHILD RESTRAINT SYSTEM - REAR FACING 7 - BOOSTER SEAT 8 - HELMET USED 9 - PROTECTIVE PADS USED (ELBOWS, KNEES, ETC) 10 - REFLECTIVE CLOTHING 11 - LIGHTING - PEDESTRIAN / BICYCLE ONLY 99 - OTHER / UNKNOWN		TRAPPED 1 - NOT TRAPPED 2 - EXTRICATED BY MECHANICAL MEANS 3 - FREED BY NON-MECHANICAL MEANS	GENDER F - FEMALE M - MALE U - OTHER / UNKNOWN		CONDITION 1 - APPARENTLY NORMAL 2 - PHYSICAL IMPAIRMENT 3 - EMOTIONAL (E.G., DEPRESSED, ANGRY, DISTURBED) 4 - ILLNESS 5 - FELL ASLEEP, FAINTED, FATIGUED, ETC. 6 - UNDER THE INFLUENCE OF MEDICATIONS / DRUGS / ALCOHOL 9 - OTHER / UNKNOWN	DRUG TEST TYPE 1 - NONE 2 - BLOOD 3 - URINE 4 - OTHER
						DRUG TEST RESULT(S) 1 - AMPHETAMINES 2 - BARBITURATES 3 - BENZODIAZEPINES 4 - CANNABINOIDS 5 - COCAINE 6 - OPIATES / OPIOIDS 7 - OTHER 8 - NEGATIVE RESULTS



OCCUPANT / WITNESS ADDENDUM

LOCAL REPORT NUMBER
22-29324

OCCUPANT

UNIT # _____ NAME: LAST, FIRST, MIDDLE _____

ADDRESS: STREET, CITY, STATE, ZIP _____

DATE OF BIRTH _____ AGE _____ GENDER _____

CONTACT PHONE - INCLUDE AREA CODE _____

INJURIES _____ INJURED TAKEN BY _____ EMS AGENCY (NAME) _____ INJURED TAKEN TO: MEDICAL FACILITY (NAME, CITY) _____ SAFETY EQUIPMENT _____

DOT-COMPLIANT MC HELMET SEATING POSITION _____ AIR BAG USAGE _____ EJECTION _____ TRAPPED _____

UNIT # _____ NAME: LAST, FIRST, MIDDLE _____

ADDRESS: STREET, CITY, STATE, ZIP _____

DATE OF BIRTH _____ AGE _____ GENDER _____

CONTACT PHONE - INCLUDE AREA CODE _____

INJURIES _____ INJURED TAKEN BY _____ EMS AGENCY (NAME) _____ INJURED TAKEN TO: MEDICAL FACILITY (NAME, CITY) _____ SAFETY EQUIPMENT _____

DOT-COMPLIANT MC HELMET SEATING POSITION _____ AIR BAG USAGE _____ EJECTION _____ TRAPPED _____

UNIT # _____ NAME: LAST, FIRST, MIDDLE _____

ADDRESS: STREET, CITY, STATE, ZIP _____

DATE OF BIRTH _____ AGE _____ GENDER _____

CONTACT PHONE - INCLUDE AREA CODE _____

INJURIES _____ INJURED TAKEN BY _____ EMS AGENCY (NAME) _____ INJURED TAKEN TO: MEDICAL FACILITY (NAME, CITY) _____ SAFETY EQUIPMENT _____

DOT-COMPLIANT MC HELMET SEATING POSITION _____ AIR BAG USAGE _____ EJECTION _____ TRAPPED _____

UNIT # _____ NAME: LAST, FIRST, MIDDLE _____

ADDRESS: STREET, CITY, STATE, ZIP _____

DATE OF BIRTH _____ AGE _____ GENDER _____

CONTACT PHONE - INCLUDE AREA CODE _____

INJURIES _____ INJURED TAKEN BY _____ EMS AGENCY (NAME) _____ INJURED TAKEN TO: MEDICAL FACILITY (NAME, CITY) _____ SAFETY EQUIPMENT _____

DOT-COMPLIANT MC HELMET SEATING POSITION _____ AIR BAG USAGE _____ EJECTION _____ TRAPPED _____

INJURIES	SAFETY EQUIPMENT USED	SEATING POSITION	AIR BAG USAGE
1 - FATAL	1 - NONE USED - VEHICLE OCCUPANT	1 - FRONT - LEFT SIDE (MOTORCYCLE DRIVER)	1 - NOT DEPLOYED
2 - SUSPECTED SERIOUS INJURY	2 - SHOULDER BELT ONLY USED	2 - FRONT - MIDDLE	2 - DEPLOYED FRONT
3 - SUSPECTED MINOR INJURY	3 - LAP BELT ONLY USED	3 - FRONT - RIGHT SIDE	3 - DEPLOYED SIDE
4 - POSSIBLE INJURY	4 - SHOULDER & LAP BELT USED	4 - SECOND - LEFT SIDE (MOTORCYCLE PASSENGER)	4 - DEPLOYED BOTH FRONT/SIDE
5 - NO APPARENT INJURY	5 - CHILD RESTRAINT SYSTEM - FORWARD FACING	5 - SECOND - MIDDLE	5 - NOT APPLICABLE
	6 - CHILD RESTRAINT SYSTEM - REAR FACING	6 - SECOND - RIGHT SIDE	9 - DEPLOYMENT UNKNOWN
	7 - BOOSTER SEAT	7 - THIRD - LEFT SIDE (MOTORCYCLE SIDE CAR)	
	8 - HELMET USED	8 - THIRD - MIDDLE	
	9 - PROTECTIVE PADS USED (ELBOWS, KNEES, ETC)	9 - THIRD - RIGHT SIDE	
	10 - REFLECTIVE CLOTHING	10 - SLEEPER SECTION OF TRUCK CAB	
	11 - LIGHTING - PEDESTRIAN / BICYCLE ONLY	11 - PASSENGER IN OTHER ENCLOSED CARGO AREA (NON-TRAILING UNIT SUCH AS A BUS, PICK-UP WITH CAP)	
	99 - OTHER / UNKNOWN	12 - PASSENGER IN UNENCLOSED CARGO AREA	
		13 - TRAILING UNIT	
		14 - RIDING ON VEHICLE EXTERIOR (NON-TRAILING UNIT)	
		15 - NON-MOTORIST	
		99 - OTHER / UNKNOWN	

WITNESS

NAME: LAST, FIRST, MIDDLE _____

ADDRESS: STREET, CITY, STATE, ZIP _____

DATE OF BIRTH _____ AGE _____ GENDER _____

CONTACT PHONE - INCLUDE AREA CODE _____

NAME: LAST, FIRST, MIDDLE _____

ADDRESS: STREET, CITY, STATE, ZIP _____

DATE OF BIRTH _____ AGE _____ GENDER _____

CONTACT PHONE - INCLUDE AREA CODE _____

NAME: LAST, FIRST, MIDDLE _____

ADDRESS: STREET, CITY, STATE, ZIP _____

DATE OF BIRTH _____ AGE _____ GENDER _____

CONTACT PHONE - INCLUDE AREA CODE _____